

Understanding Directivity

Vector Network Analyzer Measurements Models 37000X, MS4620X

Lightning™ and Scorpion™ Vector Network Analyzer

Introduction

In order to measure the quality of the impedance match of a test device (VSWR or Return Loss), the incident signal must be separated from the reflected signal. Separation of the two signals is performed by directional devices and the accuracy of the measurement is determined by the directivity of the directional devices. Directivity is defined as the ratio of the leakage of the incident signal to the desired reflected signal. The lower the leakage signal, the higher the directivity and the better the accuracy of the reflection measurement. Two devices that may be used to separate the two signals are the resistive bridge and directional coupler. This paper discusses the use and application of directional devices for impedance measurements and the factors that contribute to reflection measurement uncertainty. Additional information on Vector Network Analyzer (VNA) measurements can be obtained in other Anritsu Application Notes.



Directional Devices

The resistive bridge is constructed using the Wheatstone bridge principle. The resistive network of the Wheatstone bridge is constructed such that when a perfect 50 Ohm resistive device is connected at one leg, the bridge network is balanced. The output of the bridge is an RF signal whose amplitude is proportional to the match of the device under test (DUT); the better the match, the lower the RF amplitude. A variation on the Wheatstone bridge principle is the inclusion of a built-in detector which provides a DC output rather than RF. Anritsu pioneered this concept, known as an Autotester (Figure 1). Advantages of the Autotester are wider frequency coverage with improved directivity and the elimination of the need for an external detector. When compared to a coupler, the Autotester and bridge offer an advantage in size since the coupled lines of the coupler must be extremely long at lower frequencies. The frequency range of an Autotester can cover from 10 MHz to 50 GHz with up to 40 dB directivity. For maximum performance, Anritsu balances the Autotester over the specified frequency range with specific test port connectors for different applications. Note that adding adapters to the test port upsets the bridge balance and degrades directivity considerably, even when a high quality adapter is used. Another advantage of resistive bridges and Autotesters is that they typically have an insertion loss of about 6 dB which helps reduce re-reflections from the source. Low-loss directional devices (e.g. couplers), allow re-reflections between the source and DUT thereby increasing measurement uncertainty.

Directional couplers can provide very high directivity performance especially when designed for narrow-band applications. Coupler directivity is a function of the line spacing and electrical length of the lines. One benefit of the coupler is the insertion loss of the through path is very low. Low insertion loss provides better dynamic range. However, the low insertion loss does not reduce the re-reflections from the generator which can lead to an increase in measurement uncertainty. Directional couplers can be used to 110 GHz and beyond.

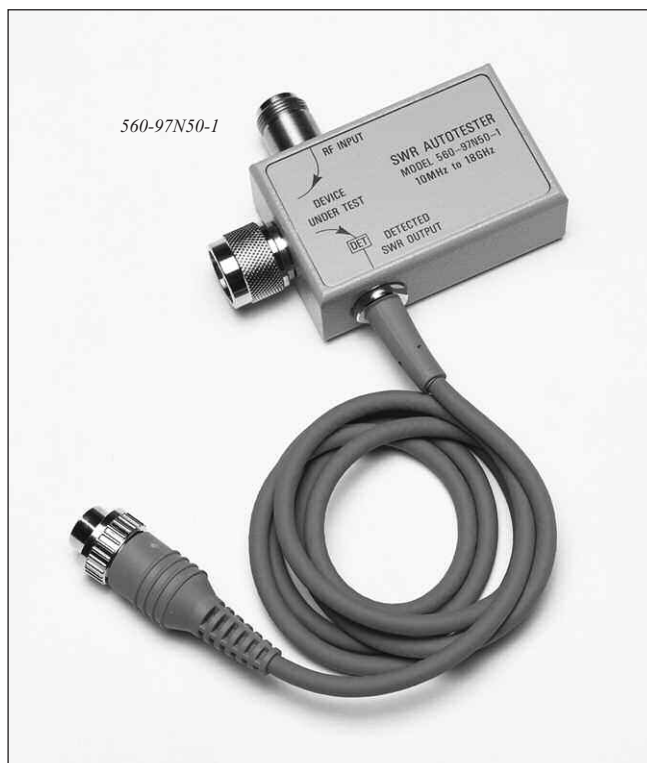

Figure 1. Anritsu Autotesters

Directional Device Performance

So how does the undesired directivity signal, which is always present to some degree, impact return loss measurements? The degree of impact depends on the relative amplitudes and phase angle between the reflected signal from the DUT and signal present due to directivity. This is the case regardless of whether the instrument used to perform the measurement is a scalar analyzer, a vector analyzer, or a spectrum analyzer with a tracking generator. Consider the two signals shown in Figure 2.

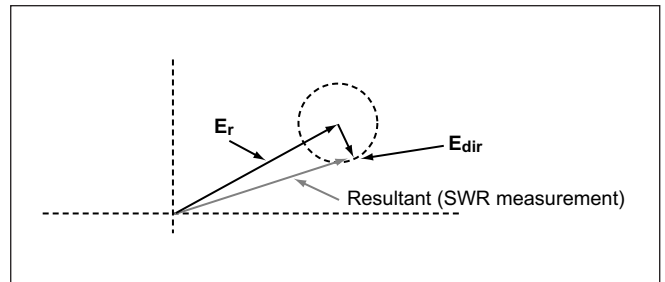

Figure 2. Interaction between the reflected signal and the directivity leakage signal.

The reflection signal from the DUT is represented by E_r and the undesired directivity signal from the directional device is represented by E_{dir} . While E_{dir} and E_r are shown as a voltage, the figure could have been drawn using power where P_r and P_{dir} are calculated from E^2/R . Units of dB are used for return loss measurements. Voltage, as shown above is used for standing wave ratio.

As the frequency is swept, E_{dir} and E_r will add and cancel causing variations in the observed signal (Figure 3). Since factors that determine the phase relationship between the two vectors, such as directivity and performance of the DUT, vary over frequency, the resultant vector is random resulting in measurement uncertainty. When performing this measurement at a single frequency, the same uncertainty applies; one cannot determine if the measurement is at the minimum, the maximum, or somewhere in between.

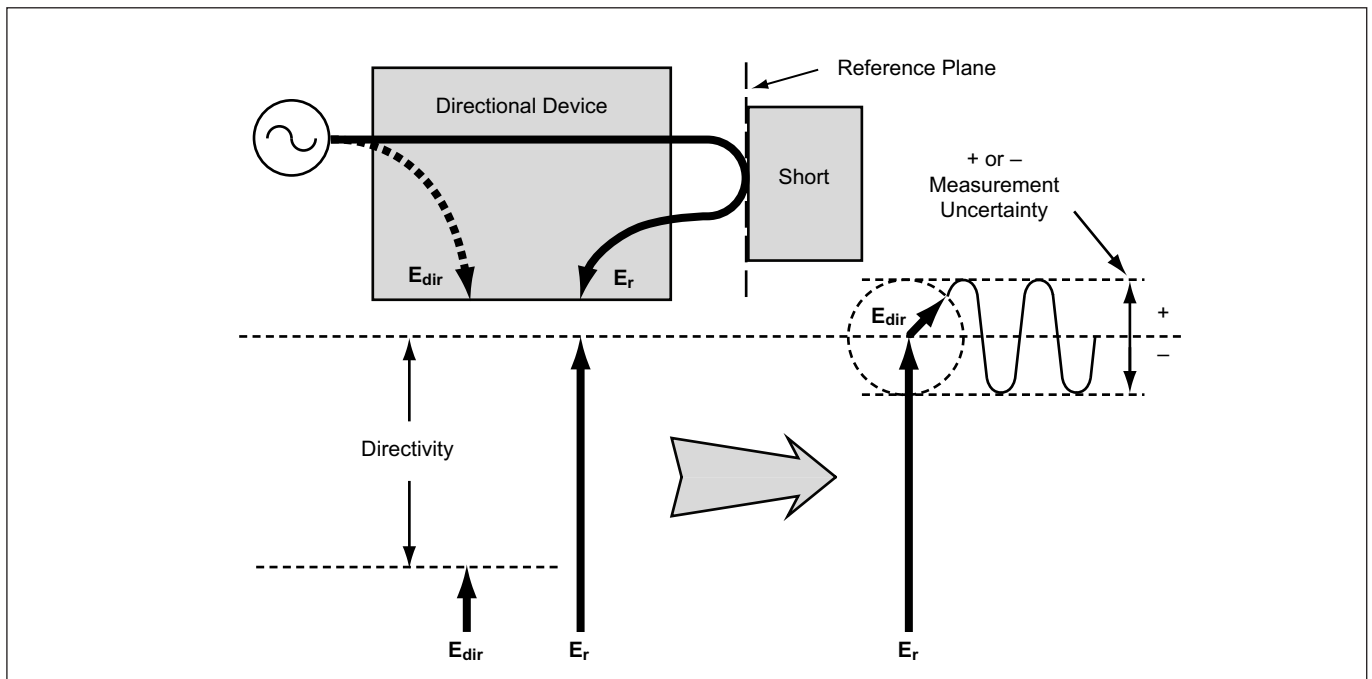

Figure 3. Measurement uncertainty as a result of directivity signal interaction.

The closer the directivity (E_{dir}) is to the reflected signal (E_r) in amplitude, the greater the peak to peak excursion and the higher the uncertainty. The min and max excursions of the resultant occur when the relative phase angles are 0 and 180 degrees. Taken to the limit where E_{dir} and E_r are exactly the same amplitude, the resultant measurement uncertainty will be at the extreme. When the two equal magnitude signals are in phase, the resultant voltage vector will double, and power will increase by a factor of four. This translates into a 6 dB reduction in return loss measurement.

When the signals are 180 degrees out of phase (and subtract) the result is “0 V”. Since we are measuring the amplitude of the reflected signal and we see no signal return, the device appears to be perfectly matched (Return Loss is infinite). In practical terms, there is a signal display as the result of noise floor and other leakages. Note the asymmetry of the min and max levels. This is borne out further by the asymmetry of the two values shown in the Return Loss Uncertainty Chart Figure 4.

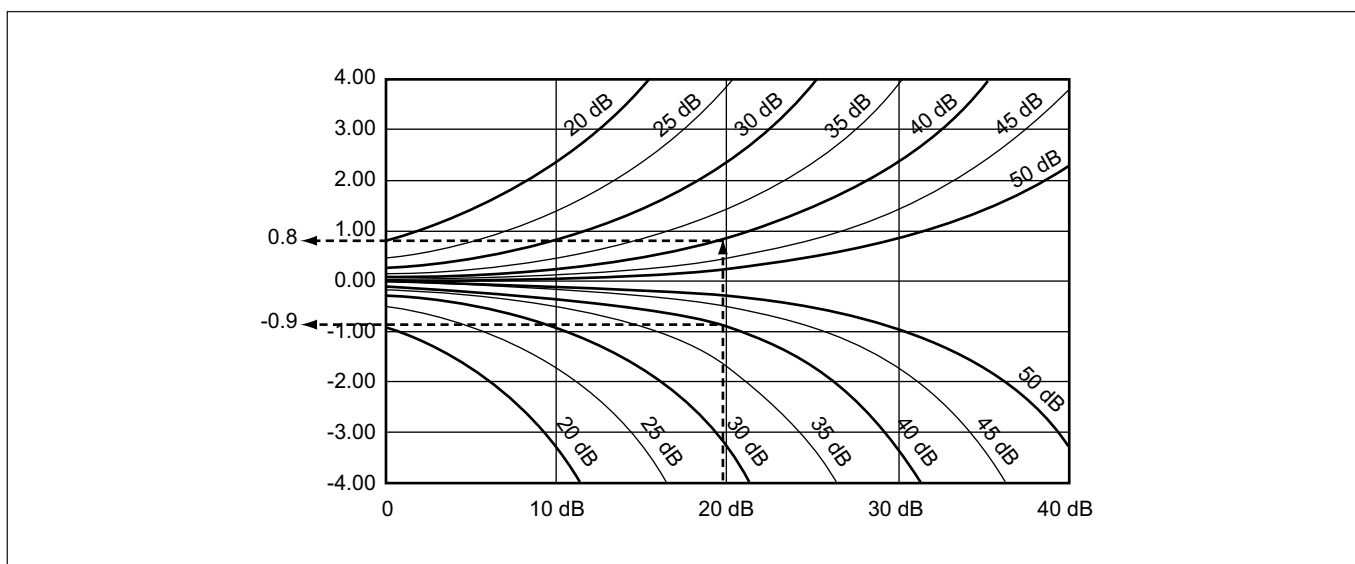

Figure 4. Return Loss Uncertainty Chart. 20 dB Return Loss measured with 40 dB directivity = -0.9 dB worst case measurement uncertainty.

Rule of thumb: when the directivity (E_{dir}) is 20 dB lower than the level of the DUT (E_r), the resultant min / max varies by nearly ± 1 dB. While this may not be an ideal situation, it is a common level of uncertainty for return loss measurements. For this reason, it is imperative that the directivity be maintained as high as possible, especially when measuring devices with return loss greater than 20 dB (requiring Directivity > 40 dB to maintain the ± 1 dB uncertainty). Directivity much greater than 42 dB is unrealistic to maintain over a wide bandwidth.

The rate of change in the relative angle between E_r and E_{dir} is a function of the frequency span and/or the electrical length separating the directivity signal from the DUT. Plotting the measurement with a long electrical length separating the directivity signal from the DUT produces a display with a prominent ripple pattern. This phenomenon can be used at an advantage to visually or mathematically separate the directivity error signal from the measurement signal of interest and thereby improve the effective directivity. This process, known as the ripple technique and pioneered by Anritsu, is used to achieve >40 dB directivity in a production environment.

Determining Reflection Measurement Accuracy

The Return Loss Uncertainty Chart (Figure 4) provides a quick method of determining measurement uncertainty for different devices. To use the chart, find the measured return loss of the device on the X axis at the bottom of the graph, move up to the first intersection of the directivity (stamped on the bridge/coupler or determined from VNA data sheet) and read the corresponding “min” on the Y axis. Continue moving up the measured return loss until intersecting the directivity again, and read the corresponding “max” on the Y axis. This min/max range is the return loss measurement uncertainty. Figure 4 demonstrates that the greater the separation between the directivity and the reflected signal, the lower the uncertainty. These curves, plotted in dB, can be mathematically translated to determine SWR uncertainty.

Vector Network Analyzer Directivity

Due to instrument complexity and wide range of frequency coverage, uncorrected VNA directivity performance is often less than typically required. In order to improve the directivity performance of the VNA, vector error correction techniques are utilized. Calibration techniques using known devices such as a Short, Open, Load, and Thru (i.e. SOLT calibration), can be used to identify the error vectors in the system. During the measurement, these error vectors are extracted and thereby improve measurement accuracy. Various calibration techniques are stored in the Anritsu VNA to facilitate the calibration process. Depending on the type of algorithm used and the quality of the calibration devices, system performance such as directivity can be vastly improved. While SOLT is a common algorithm used due to the availability of calibration components, advanced methods such as LRL/LRM can provide even further increase in measurement accuracy. In fact, using the LRL/LRM technique together with the only commercially available coaxial LRL calibration kit, the Anritsu Model 3657 Multiple-line Cal Kit, corrected directivity of 50 dB at 40 GHz is achieved.

Uncorrected (Raw) Directivity

Since directivity of a coupler is defined as the ratio of the forward leakage signal to the reflected signal of a short attached to the test port, a reduction in the amplitude of the reflected signal will reduce the directivity of the coupler. If a lossy cable is attached to the test port of the VNA in order to extend the location of the test port, then the loss of the cable will result in an attenuation of the test signal and thereby degrade directivity. Since this occurs before calibration the result is a decrease in the uncorrected directivity of the system.

Although the reduced uncorrected directivity can still be calibrated to the same performance level of a normal uncorrected system, the reduced ratio of the two signals will have an impact on calibration and measurement stability. Notice in Figure 5 how the loss of the cable reduces the amplitude of the test signal and consequently reduces the ratio of the test signal to the directivity signal. Even though the error signal is identified and subtracted by the calibration process, consider the case when the test cable is moved after calibration. Any phase change in the measurement signal will affect the phase relationship between the two signals. Now that the two signals are closer in amplitude the percent variation between the two signals will be much larger. Since this change in phase interaction between the two signals cannot be predicted or modeled, it will have a direct impact on the stability of the calibration. The result is an unstable calibration whenever the cable is moved. This is why even though the VNA calibration process corrects for system directivity, it is best to locate the DUT as close to the system directional device as possible, especially at higher frequencies where insertion loss and phase shifting is most pronounced.

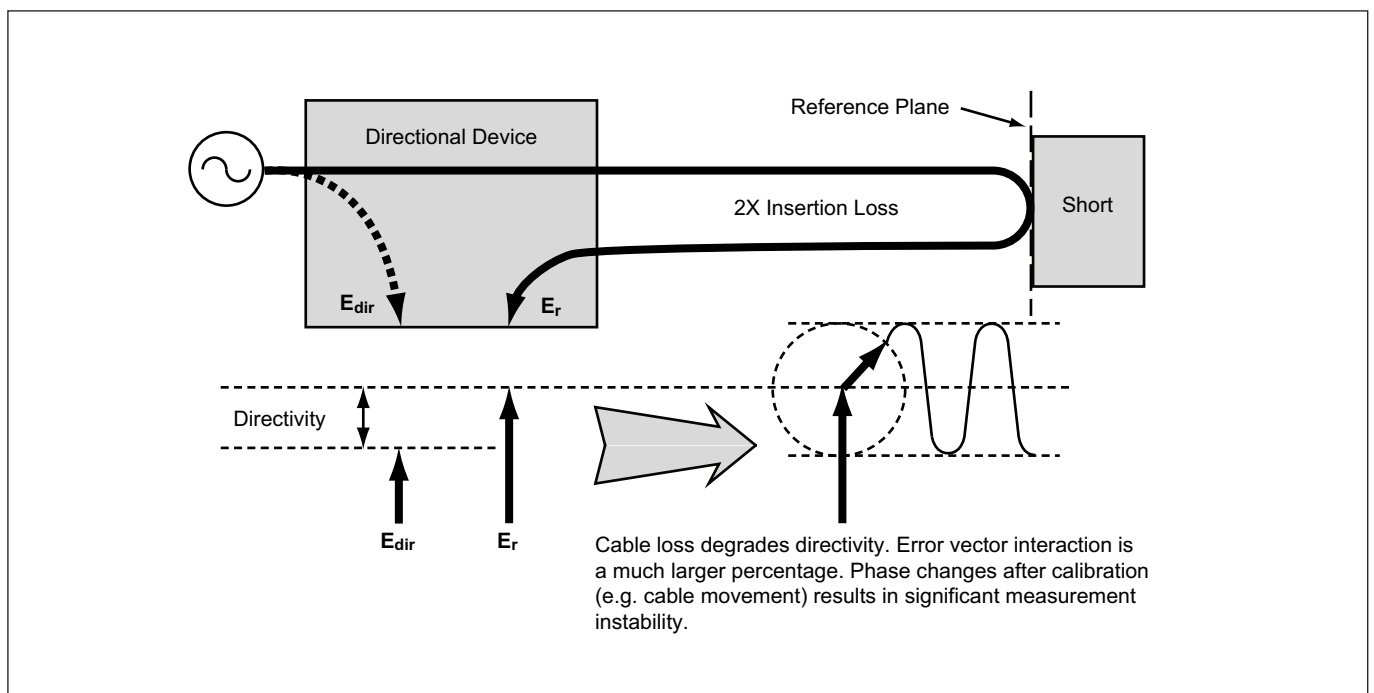

Figure 5. Moving test port away from the directional device decreases calibration stability

Additional Directional Device Considerations

- Directional devices fall into two main categories: directional resistive bridges (lumped elements) and directional couplers (distributed elements). While all four ports are designed to operate in a 50 Ohm environment, Port 3 is generally supplied with a 50 Ohm termination permanently attached when the device is to be used to measure Return Loss/SWR.
- Coupling ratio should not be confused with directivity. Coupling ratio (dB) is the nominal level of the signal at the coupled port. In Figure 6 below, Port 1 is shown as the port to which the signal is applied. At Port 3 a reduced level of the signal at Port 1 is present, reduced by the coupling ratio (10, 20, 30 dB coupling ratios are typical coupling ratios for directional couplers). Directivity, on the other hand, is the level of the signal which appears at Port 4 and is undesired. It is due to inherent imbalances in directional devices. Port 4 is the port which provides the reflected measurement (Return Loss/VSWR), when the device is configured with the DUT connected to Port 2.

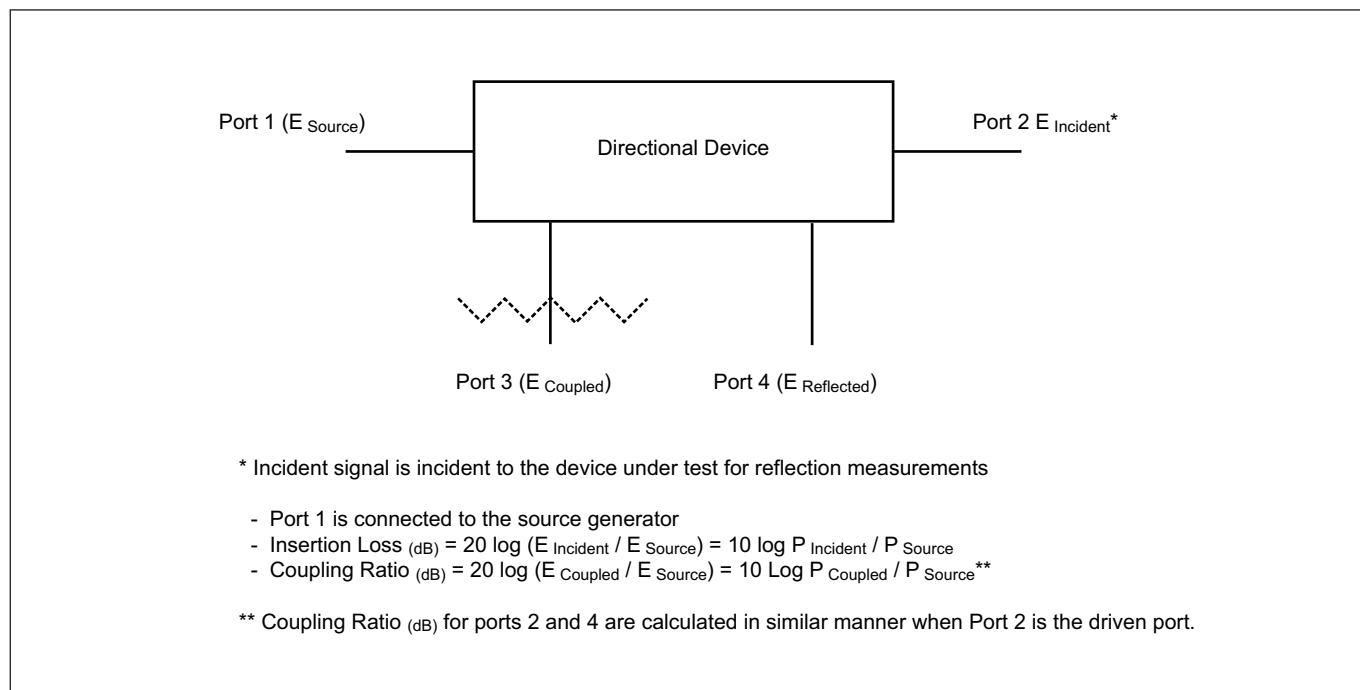

Figure 6. Four port directional device

- Directivity requires two measurements at Port 4: one with Port 2 terminated in a perfect termination and one with a perfect short. Since the coupling ratio is the same for the short and termination, it does not enter the calculation for directivity. Note that when measuring the short, coupler match will have an affect on accuracy.

$$\text{Directivity} = 20 \log E_{\text{reflected short}} / E_{\text{reflected perfect termination}} \text{ OR} \\ \text{Port 4 (dBm)}_{\text{short}} \text{ minus Port 4 (dBm)}_{\text{perfect termination}}$$

For example, the reflection port (Port 4) of a directional coupler measures -20 dBm when Port 2 is terminated with a short and -55 dBm with a perfect termination, the directivity is simply the difference of the two, 35 dB.

- Keep in mind that when the directional device has low insertion loss, the reflected signal from Port 2 can traverse back to the source where it may be reflected back to Port 2 causing ripples in the data. Waveguide couplers are notorious for re-reflections due to their extremely low loss and special techniques should be employed for testing waveguide.

Anritsu

Anritsu Corporation

5-1-1 Onna, Atsugi-shi, Kanagawa, 243-8555 Japan
Phone: +81-46-223-1111
Fax: +81-46-296-1264

• U.S.A.

Anritsu Company

1155 East Collins Boulevard, Suite 100,
Richardson, Texas 75081 U.S.A.
Toll Free: 1-800-ANRITSU (267-4878)
Phone: +1-972-644-1777
Fax: +1-972-671-1877

• Canada

Anritsu Electronics Ltd.

700 Silver Seven Road, Suite 120, Kanata,
Ontario K2V 1C3, Canada
Phone: +1-613-591-2003
Fax: +1-613-591-1006

• Brazil

Anritsu Eletrônica Ltda.

Praca Amadeu Amaral, 27-1 Andar
01327-010 - Paraiso, São Paulo, Brazil
Phone: +55-11-3283-2511
Fax: +55-11-3886940

• Mexico

Anritsu Company, S.A. de C.V.

Av. Ejército Nacional No. 579 Piso 9, Col. Granada
11520 México, D.F., México
Phone: +52-55-1101-2370
Fax: +52-55-5254-3147

• U.K.

Anritsu EMEA Ltd.

200 Capability Green, Luton, Bedfordshire LU1 3LU, U.K.
Phone: +44-1582-433280
Fax: +44-1582-731303

• France

Anritsu S.A.

16/18 Avenue du Québec-SILIC 720
91961 COURTABOEUF CEDEX, France
Phone: +33-1-60-92-15-50
Fax: +33-1-64-46-10-65

• Germany

Anritsu GmbH

Nemetschek Haus, Konrad-Zuse-Platz 1
81829 München, Germany
Phone: +49 (0) 89 442308-0
Fax: +49 (0) 89 442308-55

• Italy

Anritsu S.p.A.

Via Elio Vittorini, 129, 00144 Roma, Italy
Phone: +39-06-509-9711
Fax: +39-06-502-2425

• Sweden

Anritsu AB

Borgafjordsgatan 13, 164 40 Kista, Sweden
Phone: +46-8-534-707-00
Fax: +46-8-534-707-30

• Finland

Anritsu AB

Teknobulevardi 3-5, FI-01530 Vantaa, Finland
Phone: +358-20-741-8100
Fax: +358-20-741-8111

• Denmark

Anritsu A/S

Kirkebjerg Allé 90 DK-2605 Brøndby, Denmark
Phone: +45-72112200
Fax: +45-72112210

• Spain

Anritsu EMEA Ltd.

Oficina de Representación en España

Edificio Veganova
Avda de la Vega, nº 1 (edf 8, pl1, of 8)
28108 ALCOBENDAS - Madrid, Spain
Phone: +34-914905761
Fax: +34-914905762

• United Arab Emirates

Anritsu EMEA Ltd.

Dubai Liaison Office

P O Box 500413 - Dubai Internet City
Al Thuraya Building, Tower 1, Suite 701, 7th Floor
Dubai, United Arab Emirates
Phone: +971-4-3670352
Fax: +971-4-3688460

• Singapore

Anritsu Pte. Ltd.

60 Alexandra Terrace, #02-08, The Comtech (Lobby A)
Singapore 118502
Phone: +65-6282-2400
Fax: +65-6282-2533

• India

Anritsu Pte. Ltd.

India Liaison Office

Unit No.S-3, Second Floor, Esteem Red Cross Bhavan,
No.26, Race Course Road, Bangalore 560 001 India
Phone: +91-80-32944707
Fax: +91-80-22356648

• P. R. China (Hong Kong)

Anritsu Company Ltd.

Units 4 & 5, 28th Floor, Greenfield Tower, Concordia Plaza,
No. 1 Science Museum Road, Tsim Sha Tsui East,
Kowloon, Hong Kong, P.R. China
Phone: +852-2301-4980
Fax: +852-2301-3545

• P. R. China (Beijing)

Anritsu Company Ltd.

Beijing Representative Office

Room 1515, Beijing Fortune Building,
No. 5, Dong-San-Huan Bei Road,
Chao-Yang District, Beijing 100004, P.R. China
Phone: +86-10-6590-9230
Fax: +82-10-6590-9235

• Korea

Anritsu Corporation, Ltd.

8F Hyunjuk Bldg. 832-41, Yeoksam-Dong,
Kangnam-ku, Seoul, 135-080, Korea
Phone: +82-2-553-6603
Fax: +82-2-553-6604

• Australia

Anritsu Pty Ltd.

Unit 21/270 Ferntree Gully Road, Notting Hill
Victoria, 3168, Australia
Phone: +61-3-9558-8177
Fax: +61-3-9558-8255

• Taiwan

Anritsu Company Inc.

7F, No. 316, Sec. 1, Neihu Rd., Taipei 114, Taiwan
Phone: +886-2-8751-1816
Fax: +886-2-8751-1817

